

# Amarillo Series Fan Drive

## Model GT1712

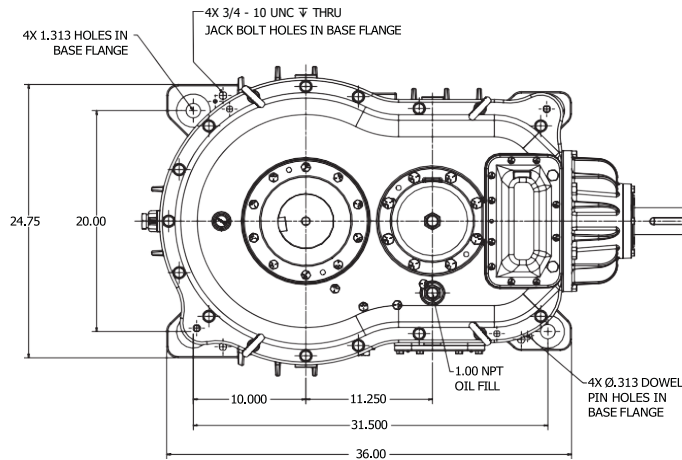

Amarillo Gear Company LLC reserves the right to make design modifications to our gear drives that may change the given dimensions. The dimensions shown in this document may not exactly reflect the dimensions of gear drives currently being offered. Request a *certified dimension print* for construction use.

**OIL PUMP (OPTION) MINIMUM CLEARANCE**  
LOCATED BENEATH THE INTERMEDIATE SHAFT.  
CONTACT THE FACTORY FOR ADDITIONAL INFORMATION AND A CERTIFIED DIMENSION PRINT.

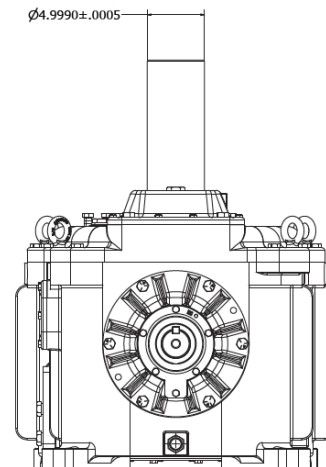
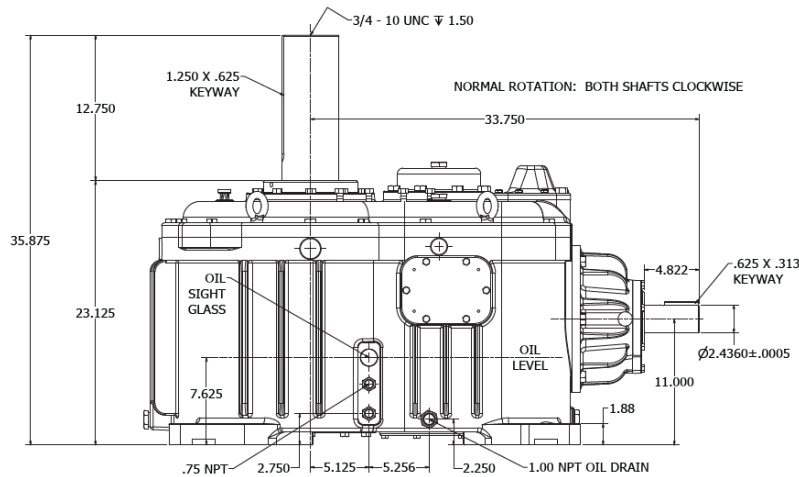
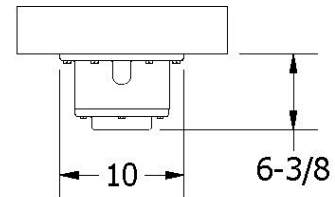

### SERVICE HORSEPOWER RATINGS (2.0 SERVICE FACTOR)

Model	Input (RPM)	Ratio								
		10	11	12	12.5	13	14	15	15.5	16
GT1712	1785	296	276	260	260	246	233	218	211	204
	1485	246	230	216	216	205	195	181	175	170
	1185	196	184	173	173	163	155	145	140	136

THRUST CAPACITY: \_\_\_\_\_ 8900 lbs.

OIL TYPE: \_\_\_\_\_ ISO VG320 / AGMA 6 / No EP additives

OIL CAPACITY: \_\_\_\_\_ 14 gallons (53 L)

WEIGHT, DOMESTIC SHIPPING: \_\_\_\_\_ 1984 lbs.

WEIGHT, EXPORT SHIPPING w/EXPORT BOX: \_\_\_\_\_ 2069 lbs.

EXPORT BOX DIMENSIONS (L x W x H): \_\_\_\_\_ 50 x 30 x 44 (inches)