



Amarillo[®]

PUMP DRIVES (30 HP THROUGH 200 HP)

INSTRUCTIONS FOR REPAIRING

Amarillo Right Angle Pump Drives, if properly installed and maintained, should provide years of service with a minimum amount of maintenance. Repairs, when required, usually involve bearing or gear replacement. While the job is not difficult, it should only be performed in an adequately equipped shop by capable personnel. It should be noted that any repairs made outside the factory on new drives without the consent of the manufacturer will void the warranty.



Catalog SPR 6/14



Amarillo[®] Gear Company LLC

Post Office Box 1789 · Amarillo, Texas 79105 · 2401 Sundown Lane (79118) 806-622-1273 · FAX 806-622-3258

www.amarillogear.com

email: info@amarillogear.com

© AGC 2014



A Marmon Water/Berkshire Hathaway Company



Amarillo®
Gear
Company LLC

T.M.

- ATTENTION -

Please note that gear drives with a serial number above 231989 have all joints sealed with Loctite Gasket Eliminator 515 instead of gaskets. Loctite 515 is a formed in place gasket material, which provides superior sealing over conventional gaskets. After disassembly for repair or inspection, we recommend resealing with Loctite 515. However, gaskets may still be used. If a gasket is utilized between the horizontal carrier and the gear case for a gear drive originally built with Loctite, the thickness of the horizontal outer spacer (550) will have to be changed to maintain the proper position of the horizontal gear. To correct the horizontal gear position, increase the horizontal spacer thickness by the thickness of the gasket. If Loctite is used to re-seal the gear drive then no changes are required to the horizontal spacer.

INSTRUCTIONS FOR REPAIRING

AMARILLO RIGHT ANGLE PUMP DRIVES

CURRENT MODELS: 30, 40A/B, 60A, 80A, 100A, 125A, 150A, 200A

NON-CURRENT MODELS: 0L40, 60, 80, 100, 125, 150

TABLE OF CONTENTS

	Page
1.0 General Disassembly Instructions	3
2.0 Disassembly of Vertical Shaft Assembly	10
3.0 Disassembly of Horizontal Shaft Assembly	11
4.0 General Assembly Instructions	12
5.0 Assembly of Parts on the Vertical Shaft	13
6.0 Assembly of Parts on the Horizontal Shaft	15
7.0 Backlash Check	17
8.0 Tooth Contact Pattern Check	20
9.0 Backlash Adjustment	22
10.0 Final Assembly	26
11.0 Disassembly and Re-assembly Instructions for Model S20, SL20, S30, and SL30.	27

1.0 General Disassembly Instructions.

Note: For disassembly of model S30 or SL30 proceed to Section 11.0.

1.1 Refer to the appropriate cross sectional drawing during disassembly and assembly.

Models	Figure No.
S40A, S40B	1
SH30, SH40A, SH40B	2
S60, S80, S100, S125, S150, S200	3
S60A, S80A, SIOOA	3
SL60, SL60A	3
SL80, SL100, SL125, SL150, SL200	4
SL80A, SLIOOA, SL125A, SL150A, SL200A	4
S125A, S150A, S200A	5
SH60, SH80, SH100, SH125, SH150, SH200	5
SH80A, SH125A, SH150A, SH200A	5

1.2 Drain and dispose of the oil.

1.3 Remove the side inspection plate (not shown).

1.4 Reach through the side inspection opening and disconnect the oil line going to the outer horizontal bearing (602).

1.5 Match mark the horizontal shaft carrier (15) and the gear case (10).

1.6 Remove the horizontal carrier (15) from the gear case (10) using the following procedure.

1.6.1 Install guide pins in two bolt holes on opposite sides of the horizontal carrier.

1.6.2 A quick jerk up and down on the end of the horizontal shaft (500) will usually pull the horizontal carrier out of the gear case. If the carrier remains in place, deliver a sharp blow using a soft mallet to the side of the shaft. This should loosen the horizontal carrier so that it can be pried out of the gear case.

1.6.3 Guide the horizontal carrier (15) assembly out of the gear case (10) using a hoist.

- 1.7 Reach through the horizontal opening left by the carrier and remove the oil line to the thrust bearing carrier (12) and the oil line to the gears.
- 1.8 Remove the top cover (11) and non-reverse clutch (24).
- 1.9 Match mark the thrust bearing cover (21) and the thrust bearing carrier (12), then remove the thrust bearing cover.
- 1.10 Some SL Models using opposed thrust bearings (see Figure 4), will have bolts and washers that retain the thrust bearings (600). If present, remove the bolts and washers.
- 1.11 If present, remove the snap ring (480) retaining the lower radial bearing (601).
- 1.12 Match mark the thrust bearing carrier (12) and the gear case (10). Remove the cap screws and eye bolts in the thrust bearing carrier. Note the position of the two eyebolts.
- 1.13 Place two eyebolts in the tapped holes in the drive sleeve (700) or driving nut (700) and slowly raise the vertical shaft assembly using a hoist. Take care not to damage the oil tube (801) or remaining oil lines.
- 1.14 Carefully set the assembly on a clean work surface, taking care not to damage the lower bearing (601).
- 1.15 If replacing the oil tube (801), remove the bottom plug (17) from the gear case (10) and replace with a new bottom plug/oil tube assembly. Coat the mating surface with Loctite gasket eliminator 515 or equivalent before installing the new bottom plug.

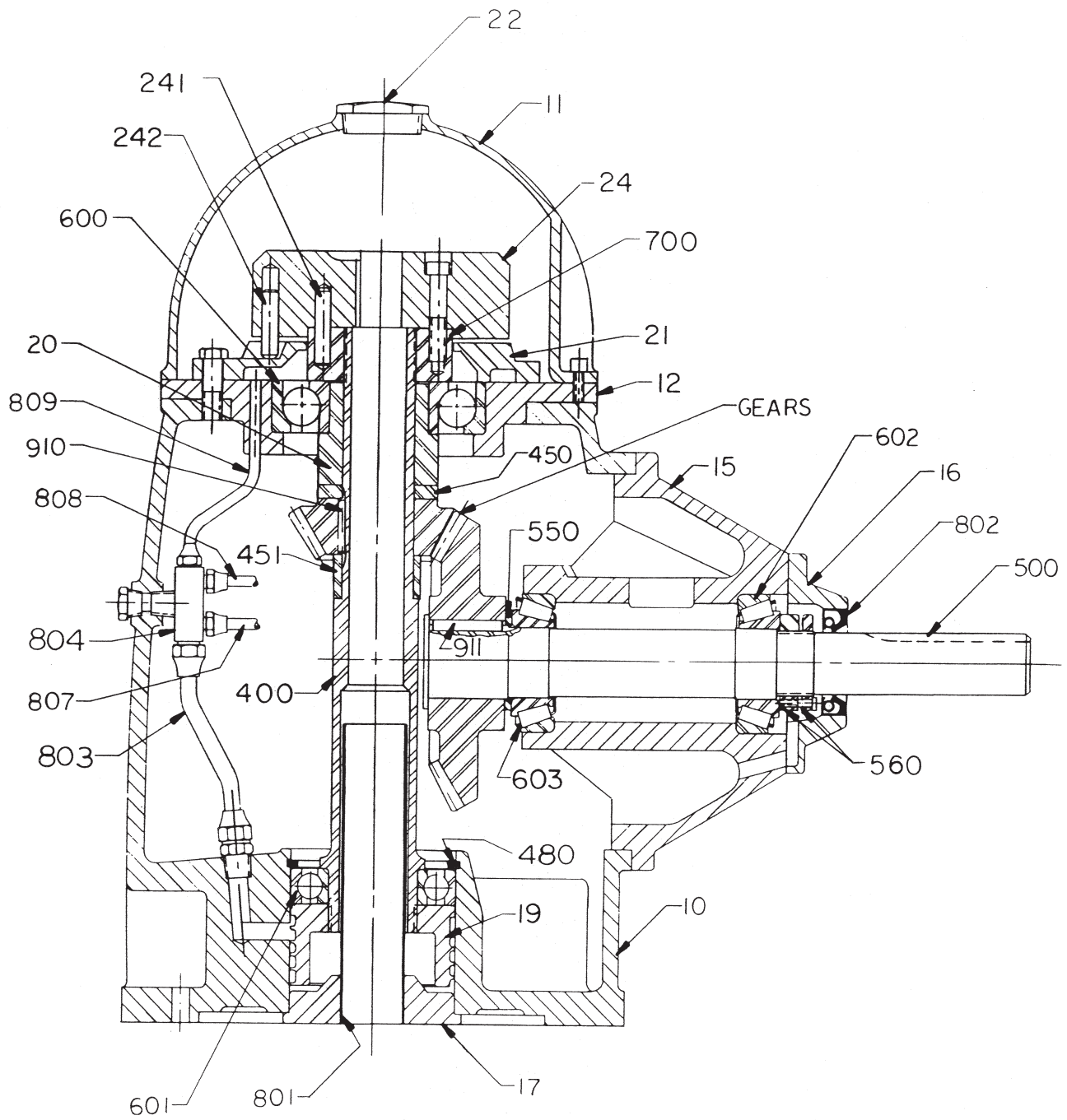

Figure 1
Single Thrust Bearing
With Driving Nut

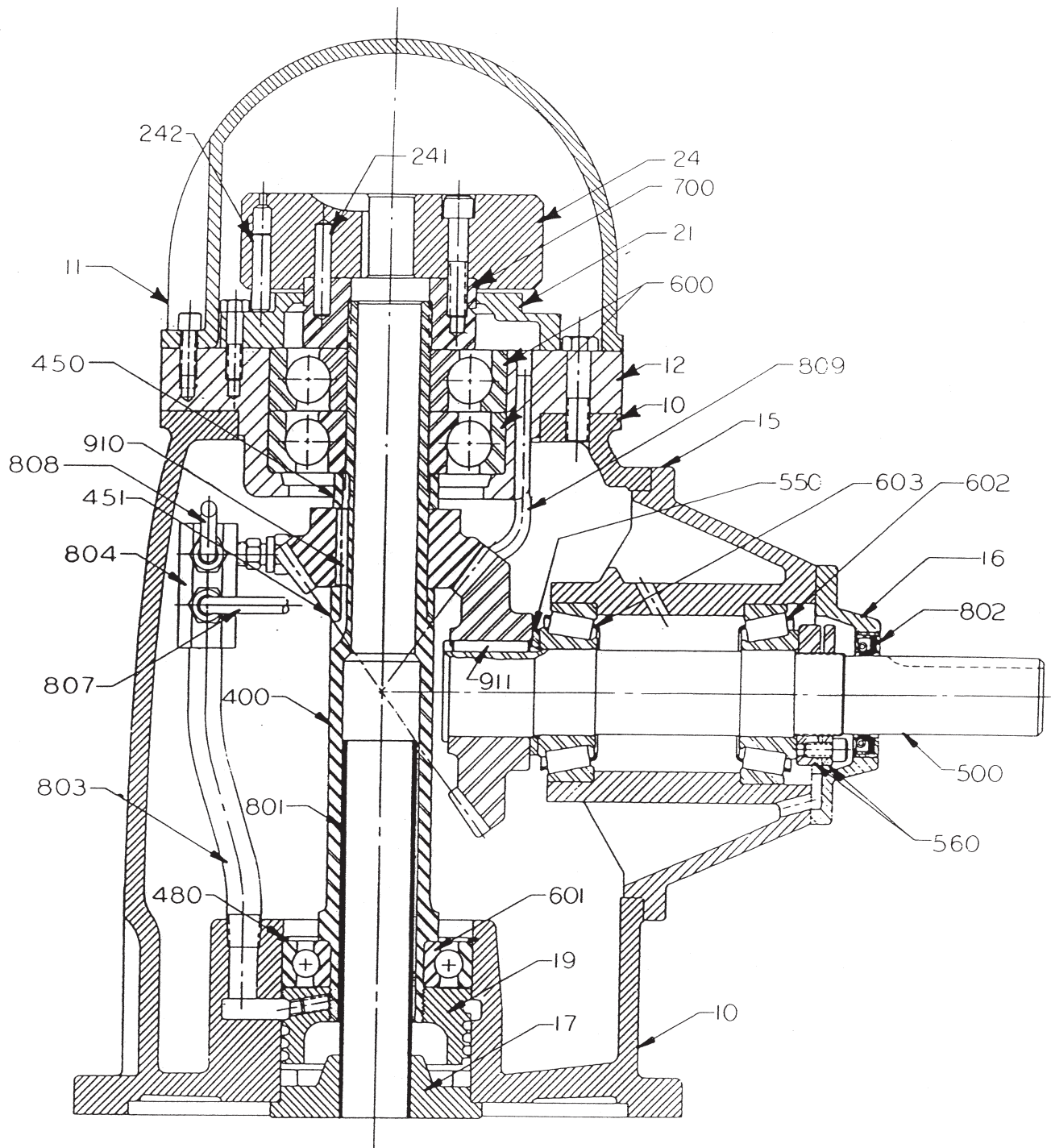

Figure 2
Stacked Thrust Bearings
With Driving Nut

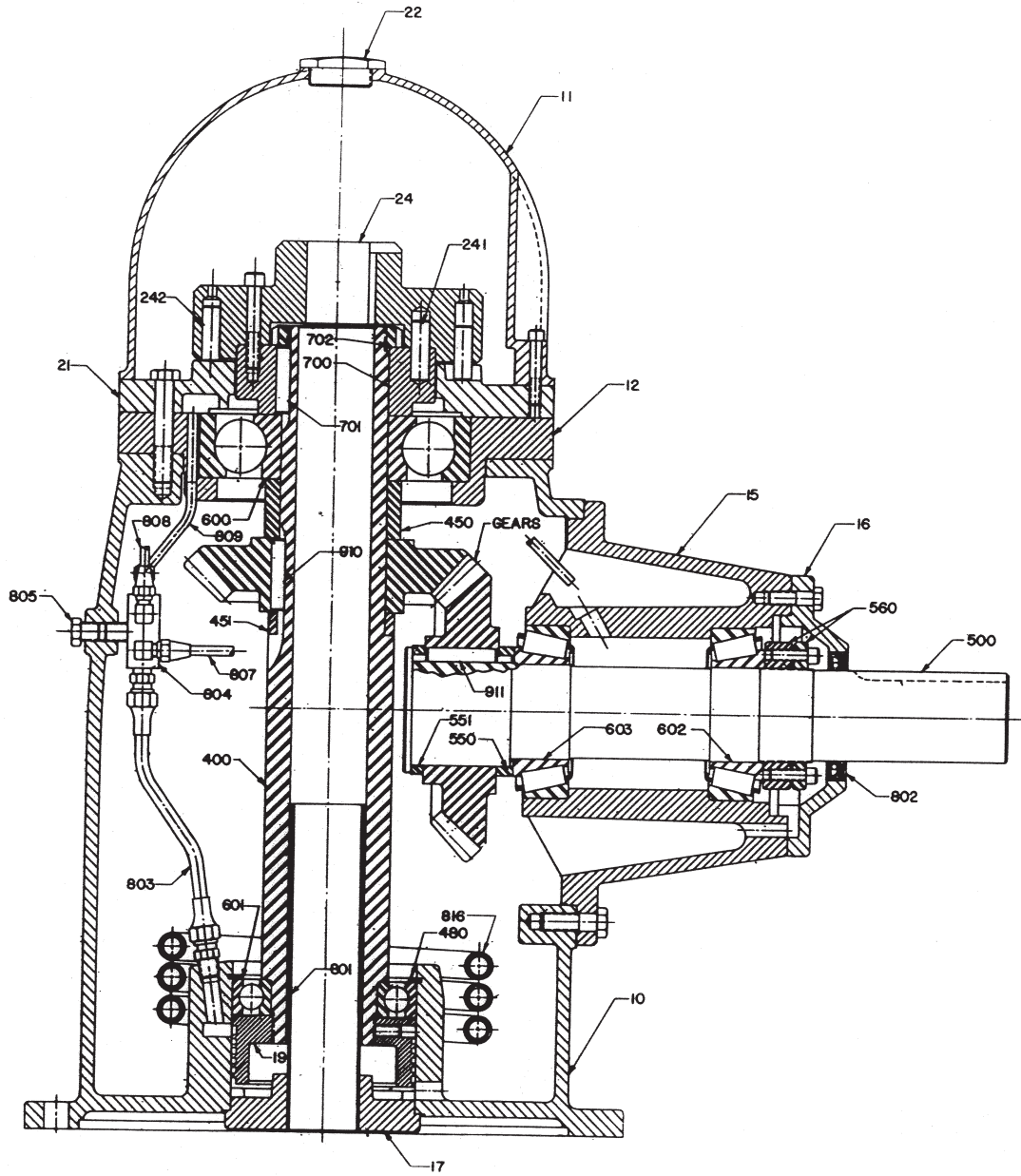

Figure 3
 Single Thrust Bearing
 With Drive Sleeve

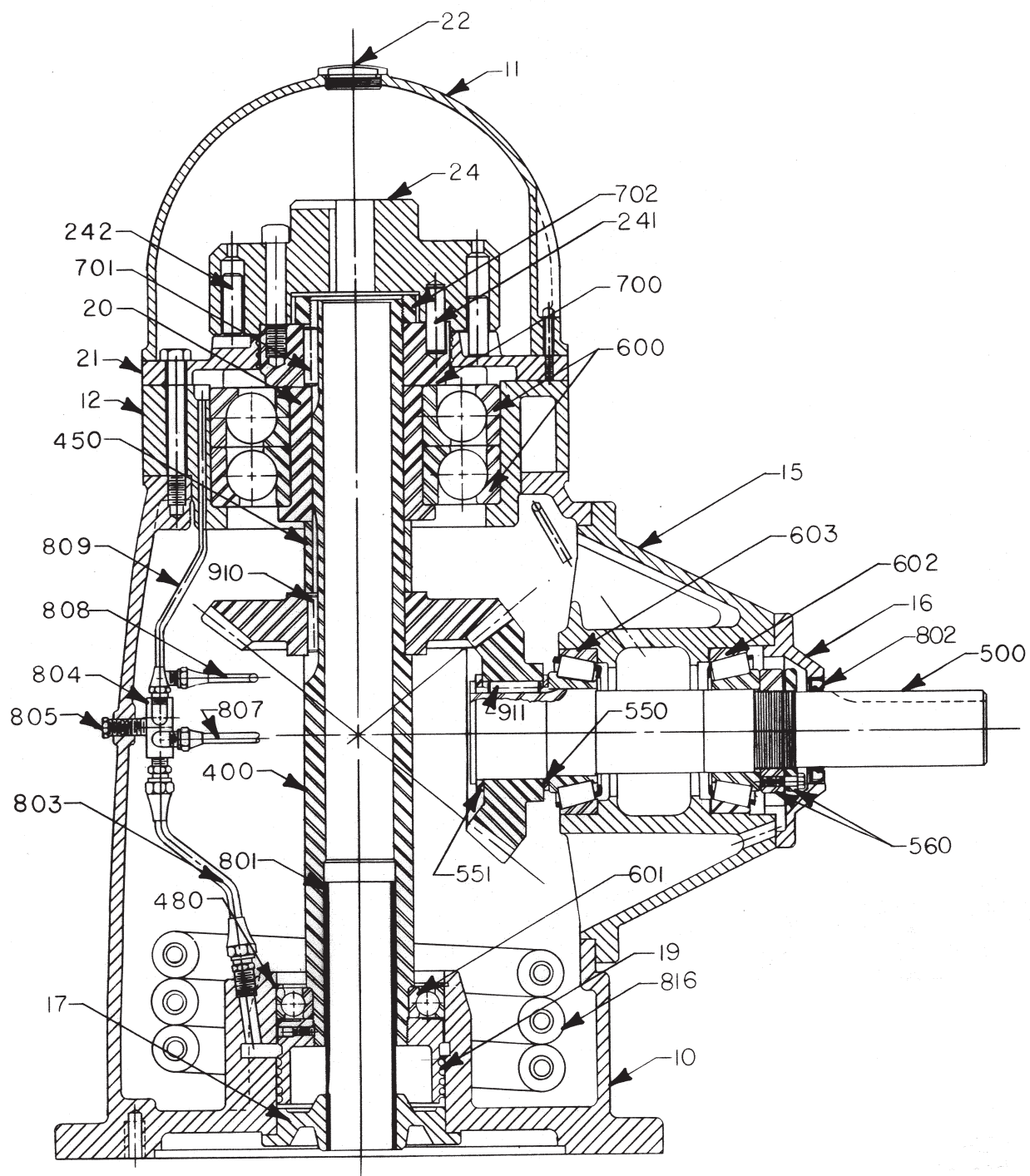

Figure 4
 Opposed Thrust Bearings
 With Drive Sleeve

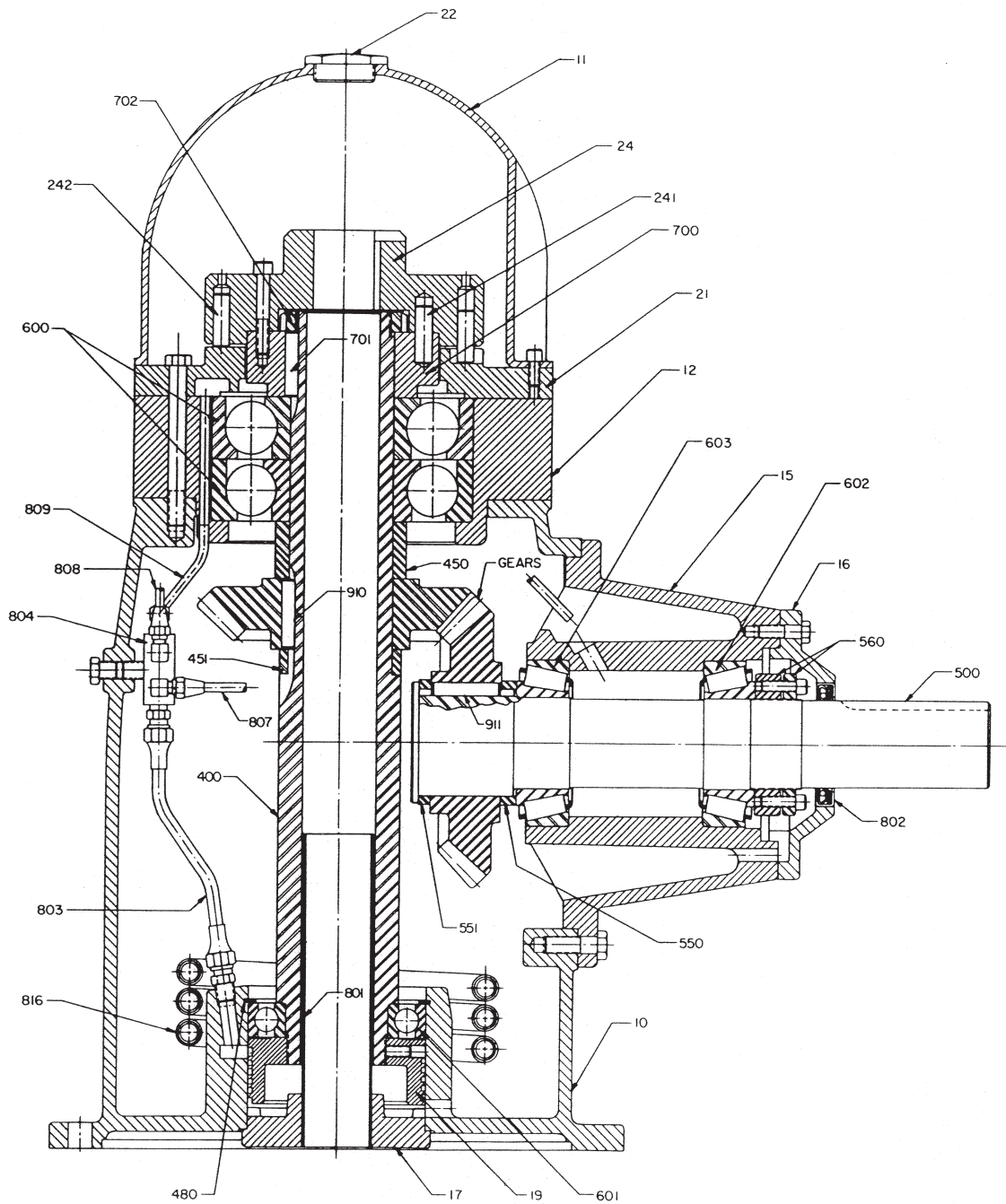

Figure 5
Stacked Thrust Bearings
With Drive Sleeve

Note: Older model 40 uses a screw-on drive nut, while the current design uses a keyless press-on drive sleeve. Drive sleeves can be identified by a machined groove on the outer diameter that is approximately 1/4" wide.

2.0 Disassembly of the Vertical Shaft Assembly.

Note: Each gear drive contains several spacers. These spacers are not interchangeable. Note the location of each spacer during disassembly to assure proper reassembly.

- 2.1 On older models using a driving nut (700) (see Figure 1 or 2), remove the driving nut using a spanner wrench or strap wrench. The driving nut has right hand threads on gear drives with CCW pump rotation and left hand threads on others. Proceed to Step 2.4.
- 2.2 On models with pressed on drive sleeves (700) (see Figure 3, 4, or 5), remove the drive sleeve locknut (702), if present, using a drift punch or spanner wrench. The drive sleeve locknut has right hand threads.
- 2.3 Using a port-a-power with a spreader bar and all thread threaded through the spreader bar and into the drive sleeve (700), pull the drive sleeve off of the shaft. Some heat may be required to make the drive sleeve easier to remove. Be careful not to overheat the drive sleeve. Remove the drive sleeve key on models 60 and larger.
- 2.4 Orient the assembly with the thrust bearing carrier (12) up and place in a press.
- 2.5 Remove the thrust bearing(s) (600) and thrust bearing carrier (12) by blocking under the thrust bearing carrier and pressing on the end of the shaft (400). Remove the vertical spacer (450).
- 2.6 If the gear is being replaced, press off the gear by blocking the gear and pressing on the end of the shaft (400). Remove the vertical shaft gear key (910) and under gear spacer (451), if present.
- 2.7 Remove the thrust bearing(s) (600) from the thrust bearing carrier (12) with a brass punch or a bearing puller.

Note: On some models the thrust bearing(s) will be pressed on a bearing bushing (20) (see Figure 1 or 4). To remove, block under the bearing bushing and press on the bearing.

- 2.8 Remove the set screw in the side of the oil screw (19).
- 2.9 Unscrew the oil screw (19) off of the vertical shaft (400) using a spanner wrench or strap wrench. The oil screw will have left hand threads.
- 2.10 Remove the lower radial bearing (601) by blocking under the inner race and pressing on the end of the vertical shaft (400).

3.0 Disassembly of the Horizontal Shaft Assembly.

- 3.1 Match mark the oil seal plate (16) and the horizontal carrier (15).
- 3.2 Remove the oil seal plate (16).
- 3.3 Loosen the horizontal locknut set (560) from the end of the horizontal shaft (500) by removing the socket head cap screws.
- 3.4 Remove the locknut set with a spanner wrench or drift punch. Remove the thinner portion first. The locknuts have right hand threads.
- 3.5 Place the horizontal assembly in a press with the pinion down. Remove the horizontal carrier (15) and outer bearing (602) by blocking under the horizontal carrier and pressing on the end of the shaft (500).
- 3.6 For models with a locknut retaining the gear (not shown) proceed as follows:
 - 3.6.1 Bend the tab of the keyed washer out of the locknut groove. Remove the locknut using a drift punch or spanner wrench. The locknut has right hand threads.
 - 3.6.2 Orient the horizontal shaft (500) vertically with the gear up. Remove the pinion by blocking under the pinion and pressing on the end of the shaft.
 - 3.6.3 Turn the horizontal shaft (500) over and remove the inner bearing cone (603) by blocking under the inner race and pressing on the end of the shaft.
- 3.7 For models without a gear retainer, use the following procedure.
 - 3.7.1 Orient the horizontal shaft (500) vertically with the pinion down.
 - 3.7.2 Remove the pinion, horizontal outer spacer (550), and inner bearing cone (603) by blocking under the pinion and pressing on the end of the shaft (500).
- 3.8 Remove the horizontal shaft gear key (911).
- 3.9 Remove the inner and outer bearing cups (602 & 603) from the horizontal carrier (15) using a brass punch or bearing puller.

4.0 General Assembly Instructions.

- 4.1 Wash all disassembled parts and housings thoroughly with clean solvent. Clean out all oil lines and passages.
- 4.2 Check the new gear set (if required) to make sure it is a matched set. Our gears are lapped in matched sets at the factory and must not be separated. Each set of gears is assigned a serial number which is etched on each member of a set. Along with the serial number, the mounting distance, part number, and minimum amount of backlash is etched on each member.
- 4.3 Do not remove bearings from their cartons until they are needed for use. Wash all bearings in clean solvent. **DO NOT** spin dry the bearings with pressurized air. Lubricate each bearing and roll the cone in its cup to check for any roughness. To protect against contamination cover a bearing that is not going to be used immediately.
- 4.4 Inspect new replacement parts to ensure that there are no burrs on shoulders that could cause assembly problems. Check for burrs on keys and keyways. Ensure that keys fit properly in keyways and have a chamfer or radius on their edges.
- 4.5 When pressing **ANY** component on a shaft or into a housing, **ALWAYS** use an anti-galling compound.
- 4.6 The correct gear positions are obtained through the use of spacers (450 & 550). **Note:** On some models the horizontal spacer is integral with the horizontal shaft (500). The required spacer lengths will vary with changes in the mounting distances (M.D.) of the gears. Spacer lengths should be changed if the M.D. of the new gear differs more than 0.003 inch from the M.D. of the old gear. Usually spacer changes are not required when replacing bearings. If the gear (10), horizontal carrier (15), or thrust bearing carrier (12) is replaced, the assembled castings will have to be re-measured and the spacers changed accordingly. For instructions on how to measure assembled castings, contact the factory.

5.0 Assembly of Parts on the Vertical Shaft.

- 5.1 Slide the under gear spacer (451), if present, onto the vertical shaft.
- 5.2 Insert the vertical gear key (910) into the vertical shaft keyway.
- 5.3 Press the gear onto the vertical shaft (400). Make sure that the gear is pressed tightly against the under gear spacer or shoulder.
- 5.4 Invert the vertical shaft (400) so that the gear is down and place the snap ring (480) over the end of the shaft. Press the lower radial bearing (601) on the shaft by pressing on the inner race of the bearing.
- 5.5 On models using a bearing bushing (20) (see Figure I or 4), press the thrust bearing(s) (600) on the bearing bushing by pressing on the inner race. **Note:** Check the appropriate-cross sectional drawing to ensure proper orientation of the thrust bearing(s).
- 5.6 Press the thrust bearing(s) (600) into the thrust bearing carrier (12). **Note:** Check the appropriate cross sectional drawing to ensure proper orientation of the thrust bearing(s).
- 5.7 Turn the vertical shaft (400) over and slide the vertical spacer (450) onto the shaft.
- 5.8 Press the thrust bearing(s) (600) with thrust bearing carrier (12) on the shaft (400). **Note:** Press only on the inner race of the bearing.
- 5.9 On older models with a driving nut (700) (see Figure I or 2), install the driving nut and hand tighten. Proceed to Step 5.13.
- 5.10 Insert the drive sleeve key (701) into the vertical shaft keyway, on models 60A and larger.
- 5.11 Press the drive sleeve (700) on the vertical shaft (400).
- 5.12 Thread the drive sleeve locknut (702), if present, on the shaft (400) and hand tighten.
- 5.13 Place the vertical assembly in a heavy vise and clamp directly below the gear. Exercise care to avoid crushing the shaft.

- 5.14 Thread the oil screw (19) onto the vertical shaft (400) and tighten securely with a spanner wrench or strap wrench.
- 5.15 Using a power drill, remove the threads on the vertical shaft that will be under the set screw. When running the drill through the set screw hole, use caution to avoid damaging the threads in the tapped set screw hole. When finished, blow the metal filings out of the hole.
- 5.16 Install the set screw to lock the oil screw (19) on the vertical shaft (400).
- 5.17 Tighten the drive sleeve locknut (702), if present, securely with a spanner wrench or drift punch or tighten the driving nut (700) securely with a spanner wrench or strap wrench.
- 5.18 Install two eyebolts in the tapped holes in the drive sleeve or driving nut (700).
- 5.19 Coat the top of the gear case (10) with Loctite Gasket Eliminator 515.
- 5.20 Using a hoist attached to the eyebolts, slowly lower the vertical assembly into the gear case (10). Take care not to damage the oil tube (801) or oil lines. Make sure the match marks on the thrust bearing carrier (12) and gear case are aligned.
- 5.21 Install the cap screws and two eyebolts in the thrust bearing carrier (12) and tighten securely. Make sure the eyebolts are placed in the same location noted in Step 1.12.
- 5.22 Install the snap ring (480), if equipped, in the groove above the lower radial bearing (601).
- 5.23 Run oil line through oil hole in thrust bearing carrier. Make sure end of oil line is flush with top of thrust bearing carrier or up to 1/8" above.
- 5.24 Connect oil line to oil supply manifold.
- 5.25. Rotate the vertical shaft (400) until the two gear teeth marked with "X" are located at the horizontal opening of the gear case (10).

6.0 Assembly of the Horizontal Shaft Assembly.

- 6.1 Press the bearing cups (602 & 603) into the horizontal carrier (15).
- 6.2 Insert the horizontal shaft gear key (911) into the shaft keyway.
- 6.3 Use the following procedure if a gear retainer (not shown) is used:
 - 6.3.1 Press the pinion on the horizontal shaft (500).
 - 6.3.2 Place the keyed washer on the end on the shaft and thread on the locknut.
 - 6.3.3 Tighten the locknut with a spanner wrench or drift punch. Bend one of the washer tabs into the locknut slot.
 - 6.3.4 Turn the shaft (500) over so that the pinion is down. Press the inner bearing cone (603) on the shaft. Take care not to damage the bearing roller cage.
- 6.4 Use the following procedure if the model does not use a gear retainer.
 - 6.4.1 Press the pinion on the horizontal shaft (500).
 - 6.4.2 Slide the horizontal inner spacer (550) on the shaft and press on the inner bearing cone (603). Take care not to damage the bearing roller cage. Ensure that the bearing seats tightly against the spacer (550).
- 6.5 Set the horizontal carrier (15) over the shaft and press the horizontal outer bearing cone (602) onto the shaft. The bearing cone should fit loosely enough to allow 0.010" to 0.020" axial movement of the horizontal carrier.
- 6.6 Thread the thicker portion of the locknut (560) on the horizontal shaft (500). **Note:** The ground surface on the thicker locknut should be installed against the outer bearing cone (602). **Do not tighten.**
- 6.7 Coat the machined surface of the horizontal carrier with Loctite Gasket Eliminator 515, making sure to coat completely around bolt holes. (See note on inside front cover) **Note:** Make sure that the timing mark ("X") on the pinion is positioned between the timing marks ("X") on the gear. Insert the horizontal assembly into gear case (10). Also make sure the match marks on the horizontal carrier and gear case are aligned. Install and tighten the cap screws.

- 6.8 Mount a dial indicator between the horizontal carrier (15) and end of the horizontal shaft (500) so that axial movement of the shaft can be measured.
- 6.9 Tighten the locknut (560) with a spanner wrench or drift punch until the in and out movement (bearing clearance) is from 0.001 to 0.002 inch T.I.R. for Models 20-150A or 0.002 to 0.003 inch T.I.R. for Model 200A. **Note:** The horizontal shaft should be rotated before each reading so the bearings will remain seated.
- 6.10 Remove the dial indicator and thread the thinner part of the locknut (560) to within 1/32 to 1/16 inch of the thicker locknut. **DO NOT** butt the two nuts together.
- 6.11 Align the holes in the locknut set (560) and insert the cap screws. Tighten the cap screws until the outer nut deflects and almost touches the inner nut.

7.0 Backlash Check.

Backlash is the amount of clearance between the mating teeth of a gear set and is obtained by measuring the amount of movement of one member at the pitch diameter, when the other member is held stationary. Backlash is very difficult to measure directly in an assembled gear drive. Following is an indirect method of measuring backlash.

- 7.1 Place a spreader bar on top of the drive sleeve locknut (702) or driving nut (700) and thread two cap screws into the thrust bearing cover (21) bolt hole circle.
- 7.2 While rotating the horizontal shaft (500), alternately tighten the cap screws until the shaft becomes difficult to rotate by hand.
- 7.3 Place a key in the horizontal shaft (500) keyway and retain with a C-clamp to eliminate any movement between the key and shaft.
- 7.4 Place a dial indicator against the key and set to zero.
- 7.5 Measure the distance from the center of the shaft (500) to the contact point between the indicator and key (see Figure 6). This is the "r" value in the equation in Step 7.7.
- 7.6 Rotate the horizontal shaft (500) back and forth and record the total indicator reading (T.I.R.). This is the "M" value in the equation in Step 7.7. **Note:** Make sure no movement occurs in the vertical shaft.
- 7.7 Calculate the backlash using the following equation. The "C" value for current models is found in Table 1 and the "C" value for outdated models is found in Table 2. For ratios or models not listed in the tables, contact the factory for the correct "C" value.

$$\text{Backlash} = \frac{(C \times M)}{r}$$

- 7.8 The amount of backlash must not be less than the amount etched on the gear set; however, the backlash may be as high as twice the etched value. If the backlash is not within the limits stated above, it must be corrected. Refer to Step 9.0 after performing the tooth contact pattern check. **NEVER** run the gears without backlash.

Table 1
Values of "C" Used in Backlash Calculations
Current Models

<u>Ratio</u>	<u>20,30</u>	<u>40A/B</u>	<u>60A,80A</u>	<u>100A</u>	<u>125A</u>	<u>150A</u>	<u>200A</u>
1:1	1.75	2.00	2.65	3.22	3.22	4.00	4.00
10:11	-	-	3.16	3.16	3.16	4.00	4.00
5:6	2.10	2.40	3.30	3.30	3.30	4.00	5.00
4:5	-	-	3.47	3.47	3.47	4.00	5.00
3:4	2.30	2.65	3.20	4.00	4.00	4.00	5.15
2:3	2.50	3.00	3.60	4.35	4.35	4.43	5.75
5:8	-	-	4.00	4.00	-	-	-
4:7	2.75	3.45	4.50	4.50	4.50	5.20	5.50
1:2	3.00	3.35	4.65	4.65	4.65	5.20	6.00
2:5	-	-	5.20	5.20	-	-	6.75
<u>1:3</u>	3.20	4.35	5.35	-	-	-	6.75
11:10	-	-	2.84	2.84	2.84	3.61	3.61
6:5	1.75	2.00	2.75	2.75	2.75	3.33	4.14
5:4	-	-	2.68	2.68	2.68	3.20	4.00
4:3	1.73	1.99	2.46	2.46	2.46	3.00	3.86
3:2	1.67	2.00	2.40	2.40	2.40	2.55	3.50
8:5	-	-	2.49	-	-	-	2.88
7:4	-	1.98	1.98	1.98	-	2.56	2.99
2:1	-	1.68	2.05	2.05	-	2.33	2.50
9:4	-	-	1.89	1.89	-	-	-
5:2	-	1.31	1.66	1.66	-	1.77	2.16
3:1	-	1.11	1.45	1.45	-	-	1.88

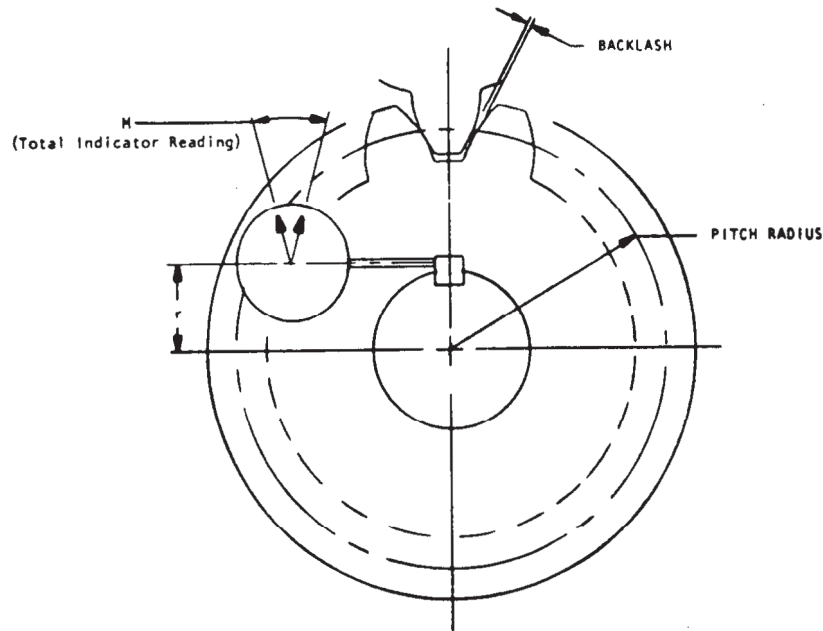

Figure 6
Backlash Check

Table 2
Values of "C" Used in Backlash Calculations
Outdated Models

<u>Ratio</u>	<u>OL40</u>	<u>60</u>	<u>80</u>	<u>100</u>	<u>125</u>	<u>150</u>	<u>200</u>
1:1	2.00	2.65	3.00	3.00	4.00	4.00	4.00
10:11	-	3.00	3.00	3.00	3.97	4.00	4.00
5:6	2.40	3.26	3.26	3.26	4.00	5.00	5.00
4:5	-	3.33	3.33	3.33	4.00	5.00	5.00
3:4	2.65	3.20	4.00	4.00	4.00	5.14	5.15
2:3	3.0	3.60	4.33	4.35	4.33	5.25	5.75
5:8	-	4.00	4.00	4.00	-	-	-
4:7	3.45	4.50	4.50	4.50	-	5.50	5.50
1:2	3.35	4.65	4.65	4.65	-	6.00	6.00
2:5	-	5.20	5.20	5.20	-	6.75	6.75
<u>1:3</u>	4.35	5.35	5.35	-	-	6.75	-
11:10	-	2.70	2.70	2.70	3.61	3.61	3.61
6:5	2.00	2.75	2.75	2.75	3.33	4.14	4.14
5:4	-	2.68	2.68	2.68	3.20	4.00	4.00
4:3	1.99	2.40	2.40	2.40	3.00	3.86	3.86
3:2	2.00	2.40	2.40	2.40	2.40	3.50	3.50
8:5	-	2.49	2.49	-	-	2.49	-
7:4	1.98	1.98	1.98	-	2.56	2.56	2.56
2:1	1.68	1.68	1.68	-	2.33	2.50	2.50
5:2	-	-	-	-	1.80	2.16	-
3:1	1.20	1.45	1.45	-	-	1.88	1.88

8.0 Tooth Contact Pattern Check

8.1 Remove the spreader bar from the top of the gear drive.

8.2 Apply a suitable marking compound to the teeth of the gears and rotate the horizontal shaft.

Note: When looking at Figures 7 through 10, make sure the orientation of the picture is consistent with the orientation of the gears in the gear drive. The "pinion" is always the smaller member in the gear set and the "gear" is the larger member of the gear set.

8.3 The correct tooth contact for a gear set is shown in Figure 7. If the tooth contact is correct, and the backlash is within limits, proceed to Step 10.0. If the tooth contact is correct, and the backlash needs to be corrected, proceed to Step 9.0.

8.4 Figure 8 shows the two most common forms of incorrect tooth contact. When a tooth contact occurs as shown in Figure 8A, check the following items.

8.4.1 For speed decreasing and 1:1 ratios, use the following procedure.

8.4.1.1 Make sure the horizontal carrier (15) is pulled up tightly to the gear case (10).

8.4.1.2* Make sure that only one gasket was used between the horizontal carrier (15) and the gear case (10).

8.4.1.3* Make sure that the gasket used between the horizontal carrier (15) and the gear case is 0.015" thick.

8.4.1.4 If the above steps do not correct the tooth contact, then the pinion will have to be moved toward the gear by increasing the thickness of the horizontal inner spacer (550). **Notes:** On some models this spacer is integral with the horizontal shaft (500). When making a new spacer, make sure that the ends of the spacer are parallel to each other and perpendicular to the bore.

8.4.2 For speed increasing ratios, the pinion will have to be moved toward the gear by increasing the thickness of the vertical spacer (450). **Note:** When making a new spacer, make sure that the ends of the spacer are parallel to each other and perpendicular to the bore.

* Disregard, if a gasket is not used.

- 8.5 When tooth contact occurs as shown in Figure 8B, check the following items.
- 8.5.1 For speed decreasing and 1:1 ratios, use the following procedure.
 - 8.5.1.1 Duplicate 8.4.1.1.
 - 8.5.1.2* Make sure that a gasket was installed between the horizontal shaft carrier (15) and the gear case (10).
 - 8.5.1.3* Make sure that the gasket used between the horizontal carrier (15) and the gear case is 0.015" thick.
 - 8.5.1.4 If the above steps do not correct the tooth contact, then the pinion will have to moved away from the gear by decreasing the thickness of the horizontal outer spacer (550). **Notes:** On some models this spacer is integral with the horizontal shaft (500). Removal of stock from the spacer must be done on a surface grinder or in a lathe with the spacer mounted on an expanding mandrel.
 - 8.5.2 For speed increasing ratios, the pinion will have to moved away from the gear by decreasing the thickness of the vertical spacer (450). **Note:** Removal of stock from the spacer must be done on a surface grinder or in a lathe with the spacer mounted on an expanding mandrel.
- 8.6 When a tooth contact occurs as shown in Figure 9 or 10, refer to the following instructions.
- 8.6.1 The most probable cause of cross contact or shaft angle error is that the horizontal carrier (15) is cocked in the register of the gear case.
 - 8.6.2 To correct, remove the horizontal assembly and check for burrs, chips, a folded gasket,* or any condition that will prevent the horizontal carrier (15) from seating flat and square on the gear case (10). Contact the factory if the problem cannot be corrected.

* Disregard, if a gasket is not used.

9.0 Backlash Adjustment

After correct tooth contact is obtained, the backlash must be rechecked according to the procedure outlined in Step 7.0.

9.1 If the backlash is less than the amount etched On the gear set, the gear will have to be moved **away** from the pinion. This is accomplished by removing stock from the appropriate spacer. **Note:** Removal of stock from the spacer must be done on a surface grinder or in a lathe with the spacer mounted on an expanding mandrel. This ensures that the ends of the spacer remain parallel to each other and perpendicular to the bore.

9.1.1 On speed decreasing and 1:1 ratio gear drives, remove material from the vertical spacer (450).

9.1.2 On speed increasing ratio gear drives, remove material from the horizontal outer spacer (550). **Note:** On some models this spacer is integral with the horizontal shaft (500).

9.2 If the backlash is more than twice the amount etched on the gear set, the gear will have to be moved **toward** the pinion. This is accomplished by increasing the length of the appropriate spacer. **Note:** When making a new spacer, make sure that the ends of the spacer are parallel to each other and perpendicular to the bore.

9.2.1 On speed decreasing and 1:1 ratio gear drives, increase the length the vertical spacer (450).

9.2.2 On speed increasing ratio gear drives, increase the length of the horizontal outer spacer (550). **Note:** On some models this spacer is integral with the horizontal shaft (500).

9.3 Use the following table to determine how much to change the appropriate spacer length. **The values given will change the backlash 0.001".**

<u>Incr. Ratio</u>	<u>Change in Horizontal Spacer Length (in.)</u>	<u>Decr. Ratio</u>	<u>Change in Vertical Spacer Length (in.)</u>
1:1	0.0020	11:10	0.0019
10:11	0.0019	6:5	0.0018
5:6	0.0018	5:4	0.0018
4:5	0.0018	4:3	0.0017
3:4	0.0017	3:2	0.0017
2:3	0.0017	8:5	0.0017
5:8	0.0017	7:4	0.0017
4:7	0.0017	2:1	0.0015
1:2	0.0015	9:4	0.0015
2:5	0.0014	5:2	0.0014
1:3	0.0014	3:1	0.0014

9.4 When the backlash is within limits, proceed to Step 10.

SPIRAL BEVEL GEARS—Typical Preferred Tooth Contact
 (Pinion Member Left Hand in All Cases Shown)

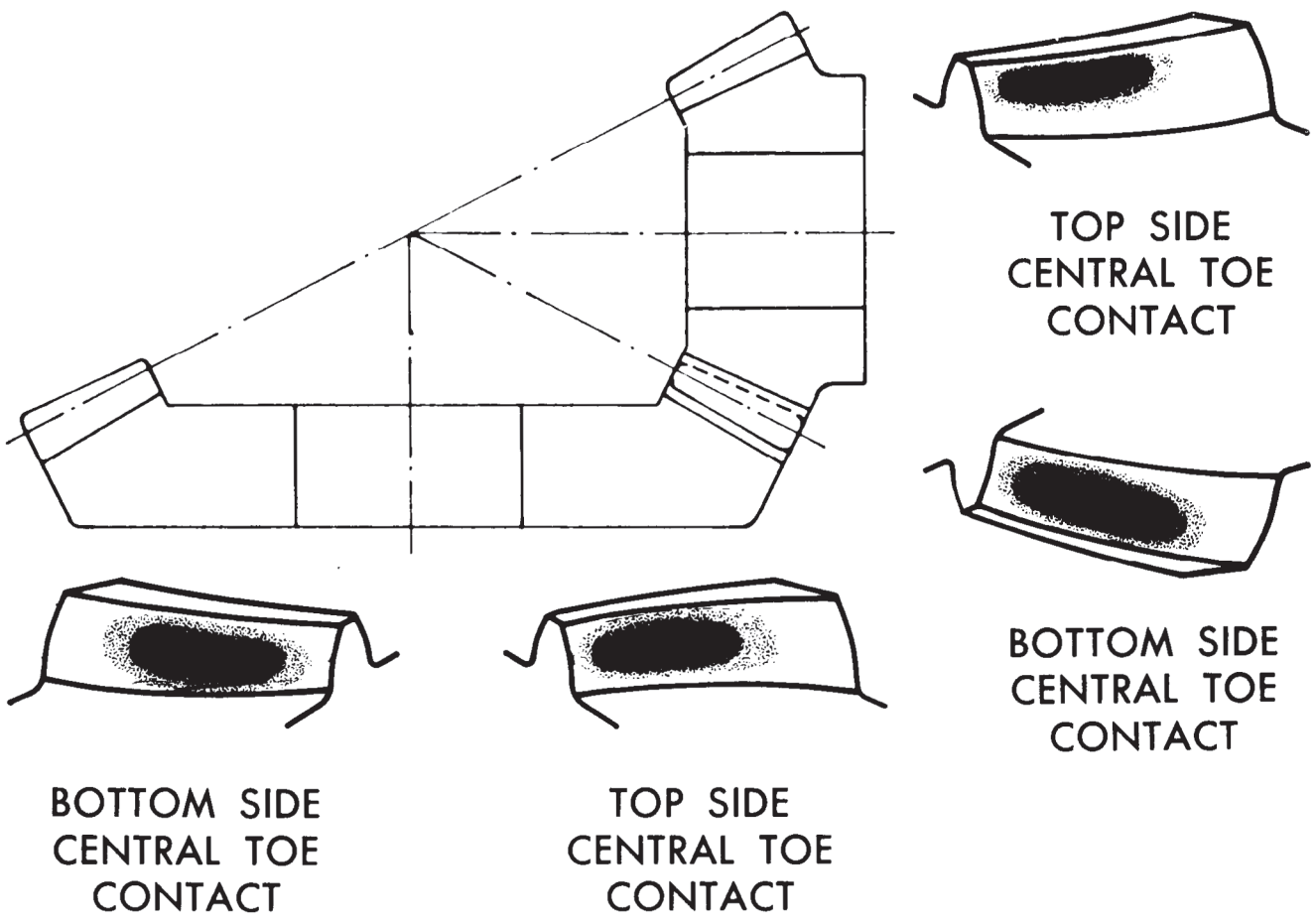

Figure 7

PROFILE ERROR—To Correct: move in on pinion cone. **PROFILE ERROR: To Correct: move out on pinion cone.**

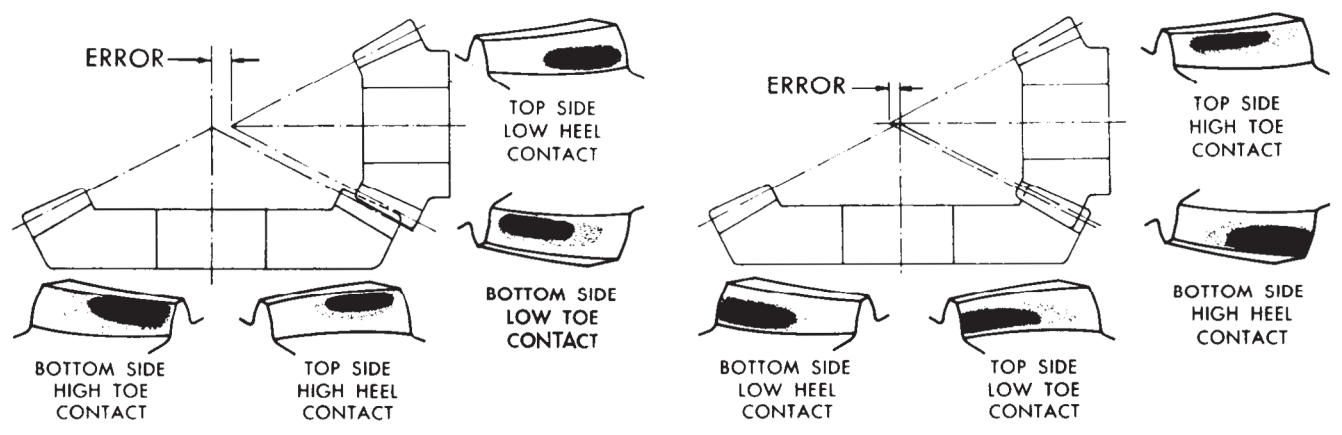
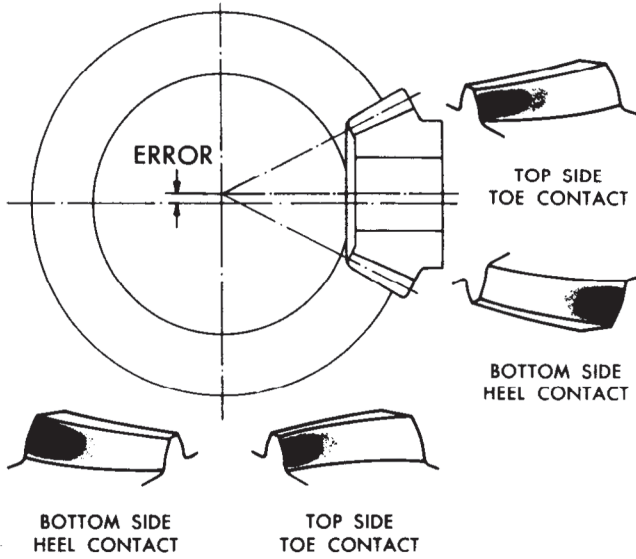

Figure 8

Proper profile contact and backlash must be obtained first before an attempt is made to correct for any of the following conditions if they should exist.

CROSS CONTACT-



CROSS CONTACT-

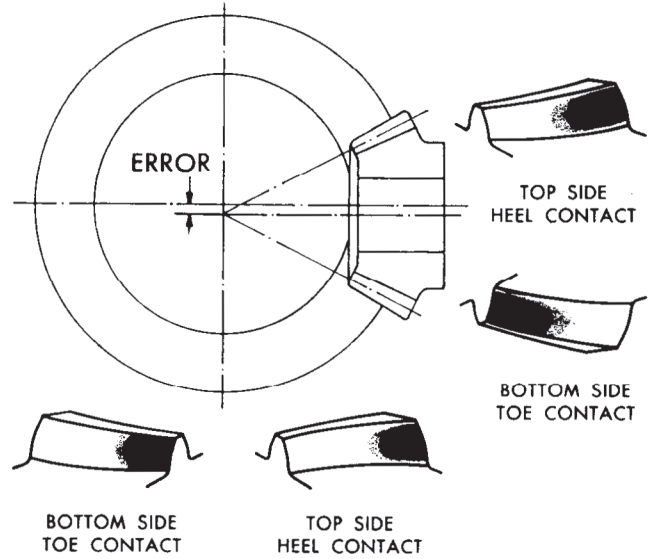
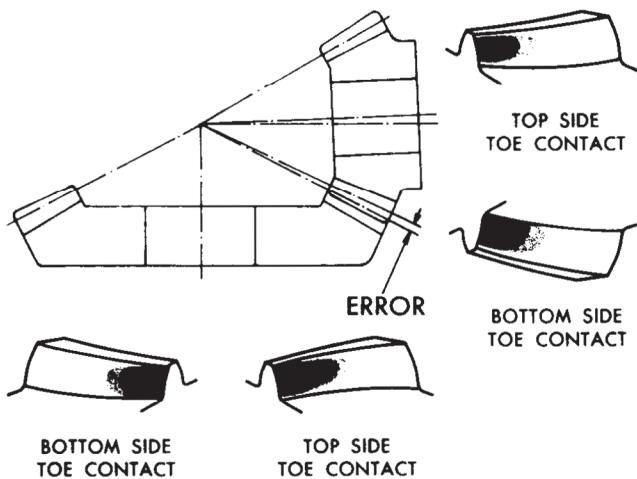

Figure 9

SHAFT ANGLE ERROR-



SHAFT ANGLE ERROR

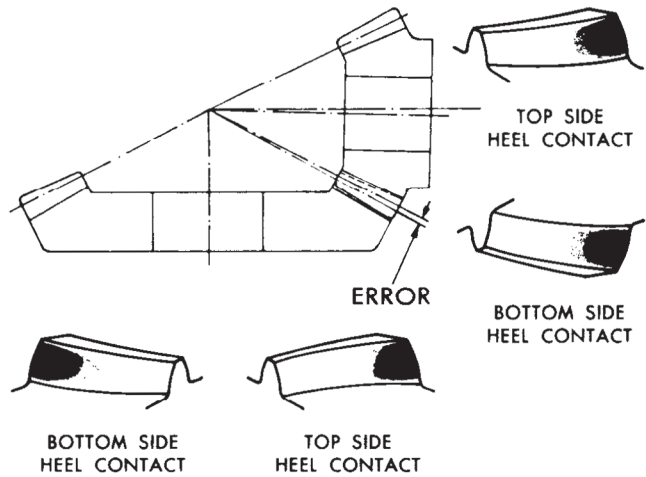

Figure 10

10.0 Final Assembly.

- 10.1 Cover the horizontal shaft keyway with tape to prevent the seal from being cut as it slides over the keyway.
- 10.2 Replace the horizontal shaft oil seal (802).
- 10.3 Coat the machined surface of the oil seal plate (16) with Loctite Gasket Eliminator 515, making sure to coat completely around bolt holes. Align the match marks and install the oil seal plate (16) on the horizontal carrier (15).
- 10.4 Reach through the side inspection port and connect the oil line that supplies the inner horizontal bearing (602).
- 10.5 Connect the oil line from the manifold to the gears. Make sure that the oil line is located from 1/3 to 1/2 of the face width back from the pinion toe. The oil line should be as close to the gear mesh as possible without interfering, with the gears.
- 10.6 Coat the machined surface of the thrust bearing cover (21) with Loctite Gasket Eliminator 515, making sure to coat completely around bolt holes. Align the match marks on the thrust bearing cover (21) and the thrust bearing carrier (12). Tighten the cap screws in the thrust bearing cover.
- 10.7 On **SL** Models using opposed thrust bearings (see Figure 4), install the thrust bearing retaining bolts and washers.
- 10.8 Using a 0.003 inch feeler, ensure that clearance exists between the thrust bearing cover (21) and drive sleeve (700) or driving nut (700).
- 10.9 Install the non-reverse clutch (24) on the drive sleeve (700) or driving nut (700). The drive pins (241) in the clutch must line up with the holes in the drive sleeve.
- 10.10 Install the cover (11.).
- 10.11 Install the inspection plate on the gear case.
- 10.12 Fill the gear drive with the proper lubricant. See the Operating and Maintenance Instructions for the proper type and amount of lubricant.
- 10.13 Return the gear drive to service.

11.0 Disassembly and Re-assembly Instructions for Model S20, SL20, S30, and SL30.

Note: Older models use a screw-on drive nut, while the current design uses a keyless press-on drive sleeve. Drive sleeves can be identified by a machined groove on the outer diameter that is approximately 1/4" wide.

- 11.1 Refer to Figure 11 during disassembly and re-assembly.
- 11.2 Perform steps 1.2 through 1.8.
- 11.3 Match mark the thrust bearing cover (21) and the gear case (10), then remove the thrust bearing cover.
- 11.4 If present, remove the snap ring (480) retaining the lower bearing (601).
- 11.5 For speed increasing ratios (i.e. 5:6, 3:4, 2:3, etc.) and 1:1 ratio, use the following procedure to remove and disassemble the vertical assembly.
 - 11.5.1 Thread two eyebolts in the drive sleeve or driving nut (700) and attach a hoist.
 - 11.5.2 Raise the hoist until the gear drive is slightly off of the work surface. Tap the top of the gear case (10) with a hammer until the thrust bearing (600) pulls out of the gear case.
 - 11.5.3 Carefully lift the vertical assembly out of the gear case. Exercise caution to avoid damaging the gear, lower bearing (601), or oil screw (19) as they pass through the gear case opening.
 - 11.5.4 Disassembly of the vertical shaft assembly is the same as outlined in Section 3.0, only disregard references to 'the thrust bearing carrier.
- 11.6 For speed decreasing ratios (i.e. 6:5, 4:3, 3:2, etc.), use the following steps to remove the vertical assembly.
 - 11.6.1 If a drive sleeve is used, proceed to 11.6.2. Clamp the base of the gear case (10) to the work surface. Hold the vertical shaft (400) with a pipe wrench and remove the driving nut (700) with a strap wrench or spanner wrench. The driving nut has right hand threads on gear drives with CCW pump rotation and left hand threads on others.
 - 11.6.2 Support the gear case (10) so that the base is approximately two inches above the work surface.
 - 11.6.3 Block between the lower bearing hub and the bottom of the gear. Press the top end of the vertical shaft (400) until the top of the lower bearing (601) passes the bottom of the gear case (10). Remove the gear. **Note:** The pusher rod between the vertical shaft and the press should have an outside diameter smaller than the inside diameter of the thrust bearing (600).

- 11.6.4 Remove the oil screw (19) and lower bearing (601) as detailed in Steps 2.8 through 2.10.
- 11.6.5 Remove the thrust bearing (600) from the gear case (10) using a brass punch or bearing puller.
- 11.7 Disassembly of the horizontal assembly is the same as described in Section 3.0.
- 11.8 Note all general assembly instructions given in Section 4.0.
- 11.9 For speed increasing ratios (i.e. 5:6, 3:4, 2:3, etc.) and 1:1 ratio, use the following procedure to assemble and install the vertical assembly.
 - 11.9.1 Assemble parts on the vertical shaft using the procedure in Section 5.0, only disregard references to the thrust bearing carrier.
 - 11.9.2 Thread two eyebolts in the drive sleeve or driving nut (700) and attach a hoist.
 - 11.9.3 Using a hoist, raise the vertical assembly over the top of the gear case (10) and carefully lower the assembly through the opening in the top of the gear case. Take care not to damage the oil tube (801) or oil screw (19).
- 11.10 For speed decreasing ratios (i.e. 6:5, 4:3, 3:2, etc.), use the following steps to assemble and install the vertical assembly.
 - 11.10.1 Press the lower radial bearing (601) on the vertical shaft (400) by pressing on the inner race of the bearing.
 - 11.10.2 Install the oil screw (19) on the vertical shaft (400) by following Steps 5.13 through 5.16.
 - 11.10.3 Block under the gear case so that it is approximately four inches above the table of the press. The bottom plug (17) should still be removed from the gear case.
 - 11.10.4 Lower the vertical shaft (400) with lower bearing (601) and oil screw (19) through the top opening in the gear case. Guide the oil screw and lower bearing through the bottom hub and let the oil screw rest on the press table.
 - 11.10.5 Place the snap ring (480), under gear spacer (451, if present), and then the gear through the horizontal opening and over the top end of the vertical shaft.

- 11.10.6 With a pusher tube placed on the top side of the gear and extending through the top of the gear case (10), press the gear on the vertical shaft (400).
- 11.10.7 Lift the vertical assembly up until the lower bearing (601) is flush with the bottom hub. Block under the oil screw (19) to hold the vertical assembly in this position.
- 11.10.8 Place the vertical spacer (450) on the vertical shaft (400) and press the thrust bearing (600) on the shaft and into the gear case (10). Make sure that the vertical spacer is pressed tightly against the shoulder on the shaft.
- 11.10.9 Remove the block from under the oil screw (19) and continue pressing the thrust bearing (600) until the lower side is pressed tightly against the gear case.
- 11.10.10 If a drive sleeve is used, press in on the vertical shaft until it is tight against the thrust bearing.
- 11.10.11 Install the lower bearing retaining ring (480). **If a drive sleeve was pressed on in Step 11.10.10, proceed to Step 11.10.14.**
- 11.10.12 Remove the gear drive from the press and clamp the gear case (10) to a clean work surface.
- 11.10.13 Hold the vertical shaft (400) with a pipe wrench and securely tighten the driving nut (700) using a spanner wrench or strap wrench.
- 11.10.14 Unclamp the gear drive and turn it over on its side.
- 11.10.15 Coat the mating surface of the bottom plug (19) with Loctite Gasket Eliminator 515 and install the bottom plug/oil tube assembly in the gear case (10) using a soft mallet.
- 11.11 Connect the oil line (808) to the thrust bearing (600).
- 11.12 Rotate the vertical shaft (400) until the two gear teeth marked with "X" are located at the horizontal opening of the gear case (10).
- 11.13 Follow the steps in Section 6.0 for assembly of the horizontal shaft assembly.
- 11.14 Backlash check, tooth contact pattern check, backlash adjustment, and final assembly is the same as outlined in Sections 7.0 through 10.0.

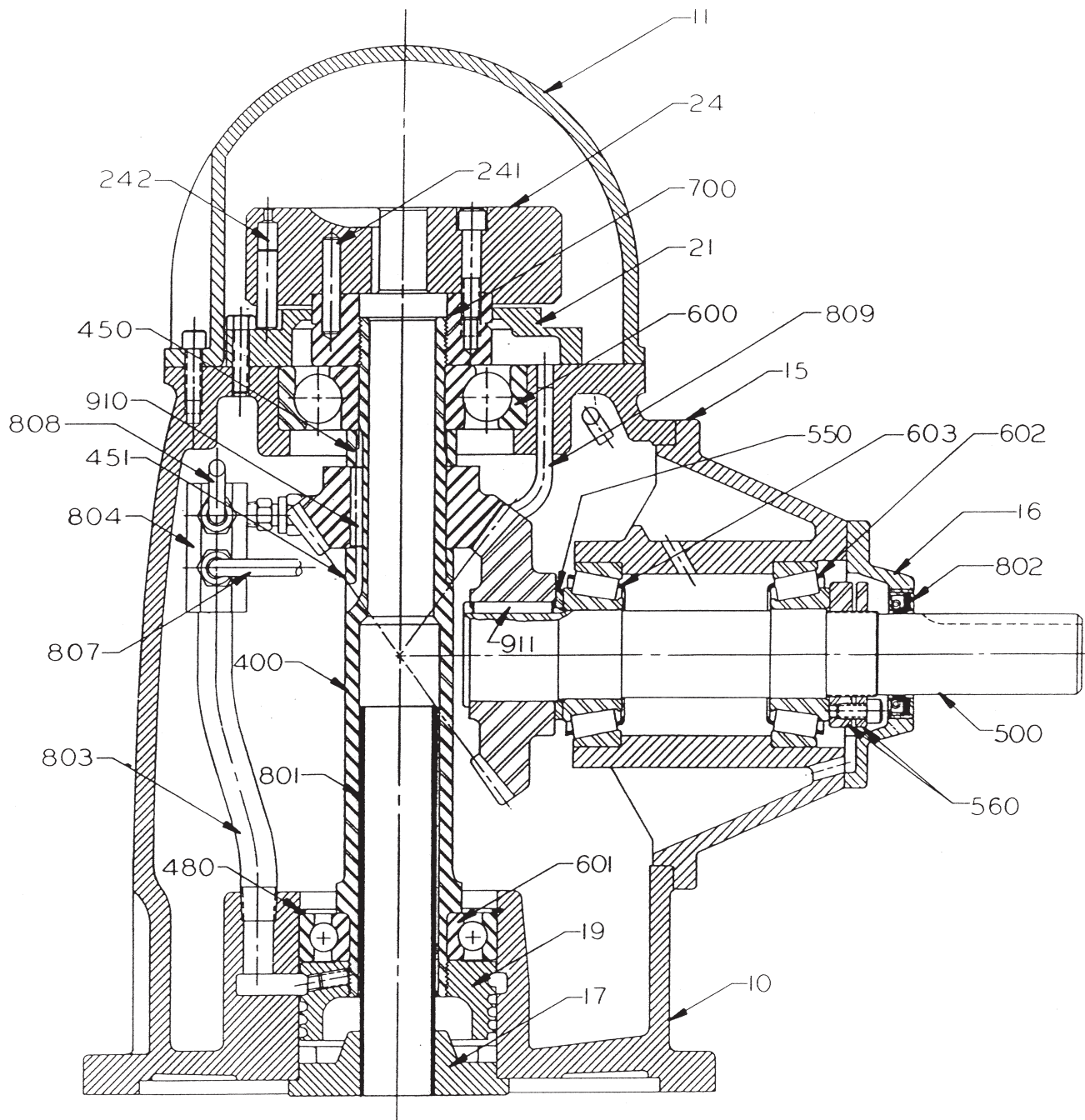

Figure 11
Model S30, SL30 Cross Section



Amarillo[®]
Gear
Company LLC

T.M.



Amarillo[®] Gear Company LLC

Post Office Box 1789 · Amarillo, Texas 79105 · 2401 Sundown Lane (79118) 806-622-1273 · FAX 806-622-3258

www.amarillogear.com

email: info@amarillogear.com

© AGC 2014



A Marmon Water/Berkshire Hathaway Company