

# Amarillo Series Fan Drive

## Model 1713A

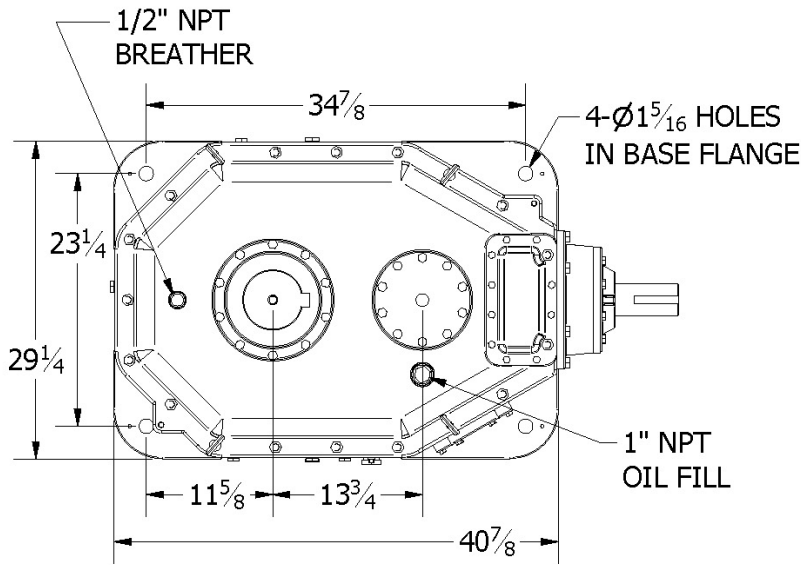

Amarillo Gear Company LLC reserves the right to make design modifications to our gear drives that may change the given dimensions. The dimensions shown in this document may not exactly reflect the dimensions of gear drives currently being offered. Request a *certified dimension print* for construction use.

**OIL PUMP (OPTION) MINIMUM CLEARANCE**  
LOCATED BENEATH THE INTERMEDIATE SHAFT.  
CONTACT THE FACTORY FOR ADDITIONAL  
INFORMATION AND A CERTIFIED DIMENSION PRINT.

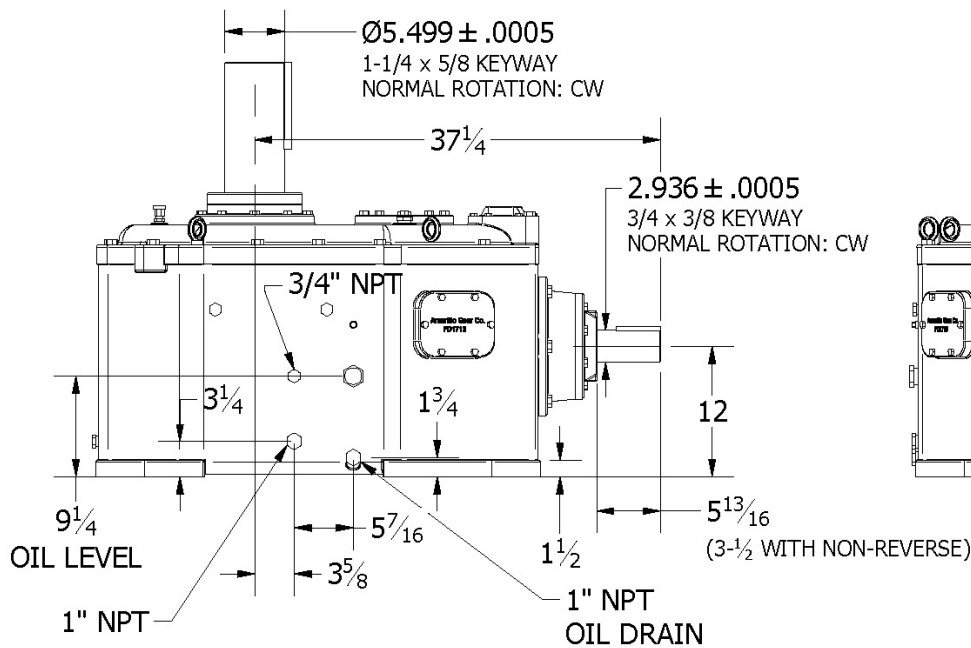
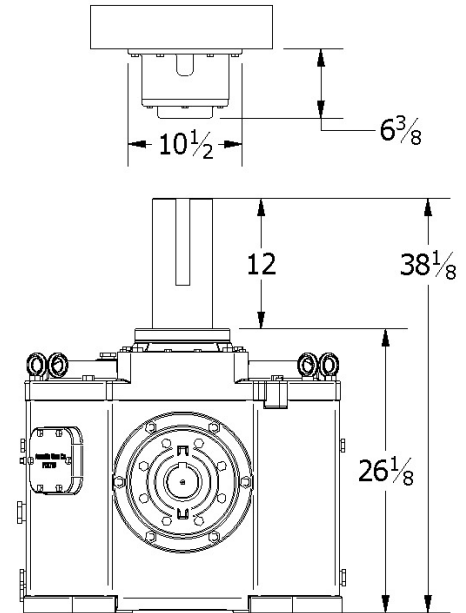

### SERVICE HORSEPOWER RATINGS

(2.0 SERVICE FACTOR)

Input (RPM)	Nominal Ratio											
	11	12	12.5	13	14	15	15.5	16	17	18	19	20
1750	390	343	333	323	310	300	294	285	272	262	250	241
1450	323	284	276	268	257	249	244	236	225	217	207	200
1160	259	227	220	214	205	199	195	189	180	174	166	160

THRUST CAPACITY: \_\_\_\_\_ 10900 lbs.  
 OIL TYPE: \_\_\_\_\_ ISO 220 / AGMA 5 or 5S / No EP additives  
 OIL CAPACITY: \_\_\_\_\_ 24 gallons (91 L)  
 WEIGHT, DOMESTIC SHIPPING: \_\_\_\_\_ 2775 lbs.  
 WEIGHT, EXPORT SHIPPING w/EXPORT BOX: \_\_\_\_\_ 3020 lbs.  
 EXPORT BOX DIMENSIONS (L x W x H): \_\_\_\_\_ 55 x 41 x 45 (inches)