

Amarillo Series Fan Drive

Model A40

Amarillo Gear Company LLC reserves the right to make design modifications to our gear drives that may change the given dimensions. The dimensions shown in this document may not exactly reflect the dimensions of gear drives currently being offered. Request a *certified dimension print* for construction use.

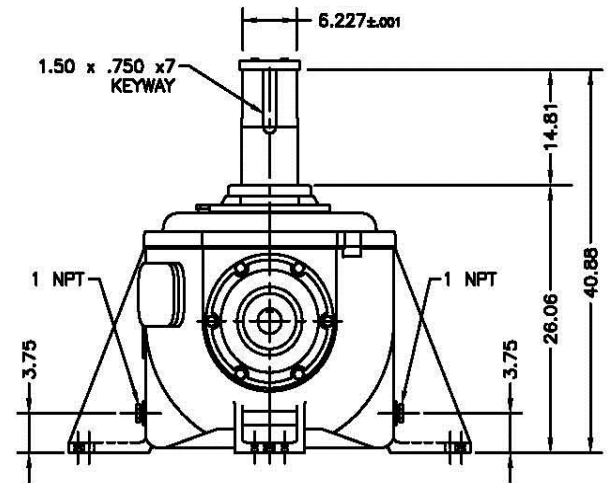
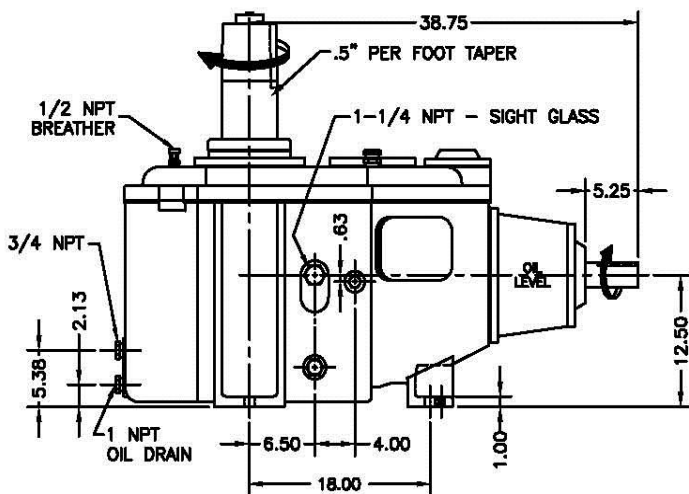
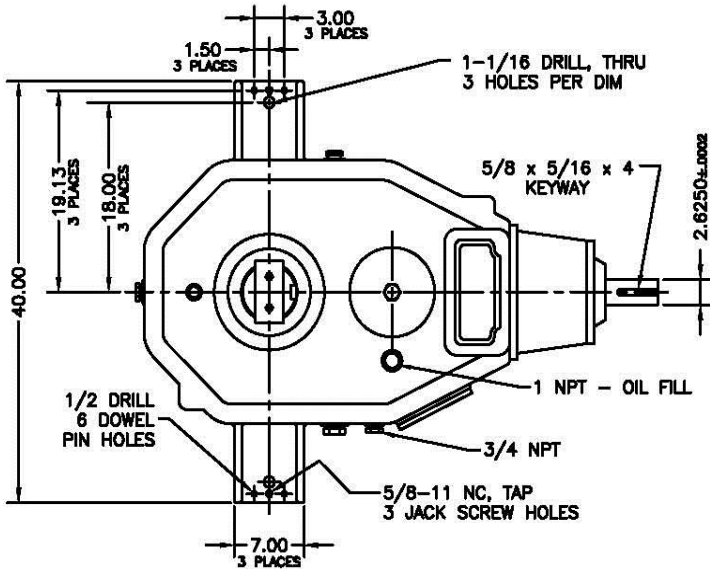

SERVICE HORSEPOWER RATINGS (2.0 SERVICE FACTOR)

Input (RPM)	Nominal Ratio									
	9.64	10.83	11.55	12.18	12.98	13.24	13.81	14.88	15.84	16.49
1750	360	343	330	323	305	300	289	265	252	230

OIL TYPE: _____ ISO 220 / AGMA 5 or 5S / No EP additives
 OIL CAPACITY: _____ 21 gallons (79 L)
 WEIGHT, DOMESTIC SHIPPING: _____ 2380 lbs.
 WEIGHT, EXPORT SHIPPING w/EXPORT BOX: _____ 2560 lbs.
 EXPORT BOX DIMENSIONS (L x W x H): _____ 58 x 46 x 45 (inches)

Amarillo Gear Company can provide a matching output shaft when necessary. A shaft drawing or schematic information will be necessary. See catalog for further details.