

# Single Reduction Gear Drive Typical Cross-Section

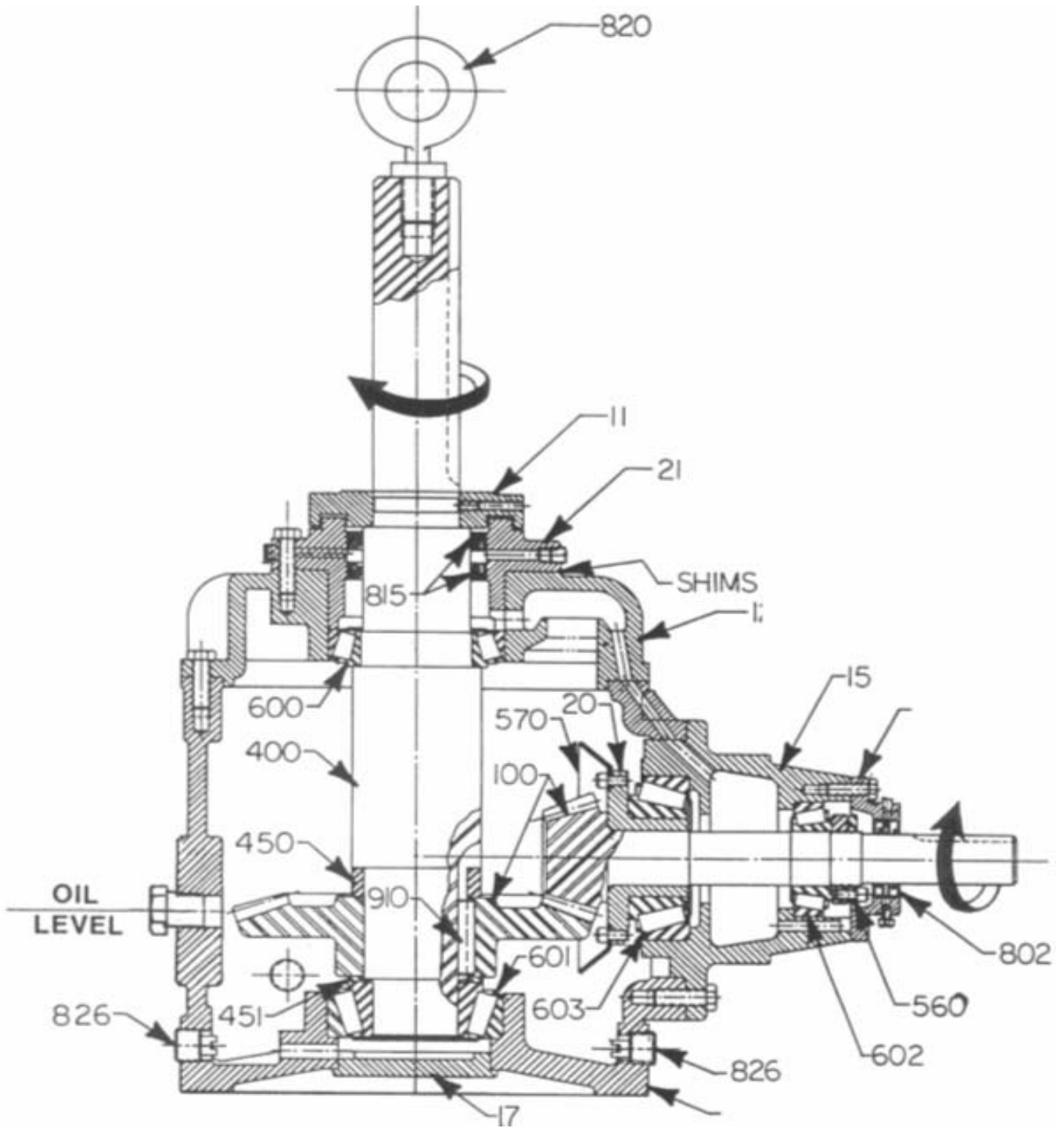

# Double Reduction Gear Drive Typical Cross-Section

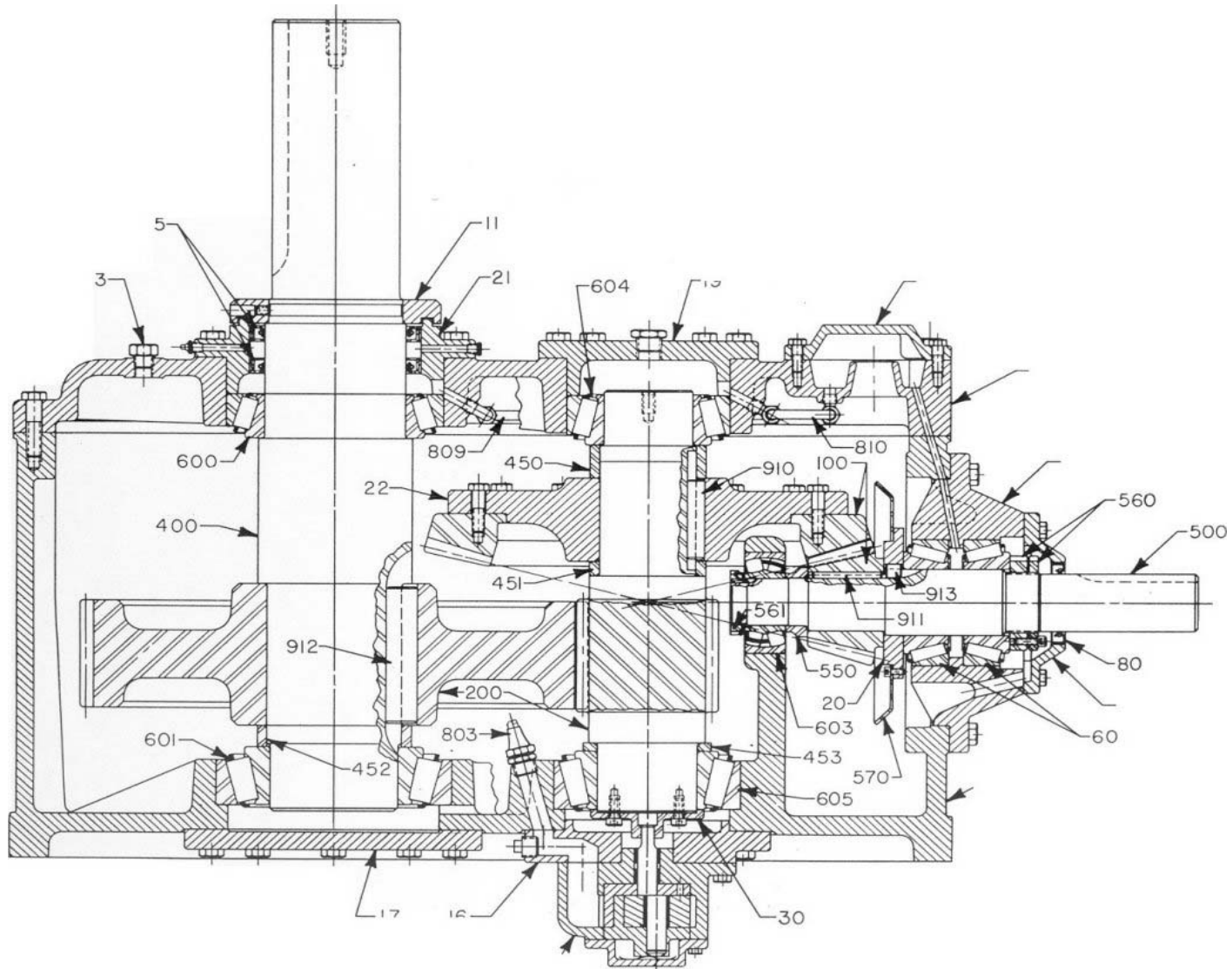

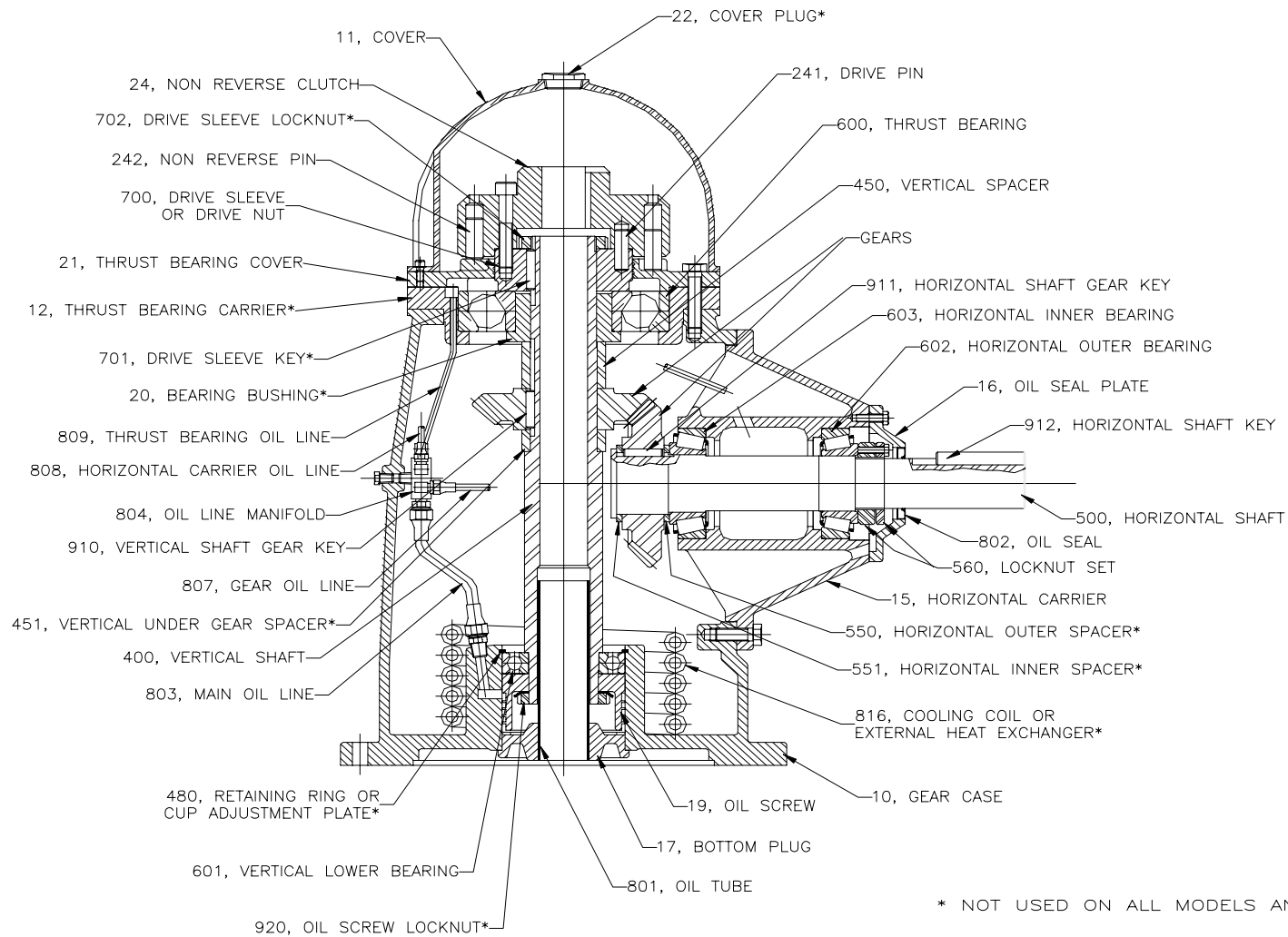

DR.BY: R. ADAMS  
 CK.BY:  
 APP.BY:

**AMARILLO  
 GEAR  
 COMPANY**

TYPICAL  
 CROSS  
 SECTION

MODEL:	20-350
DATE:	11/4/02
PART NO.	
DWG NO.	A5019

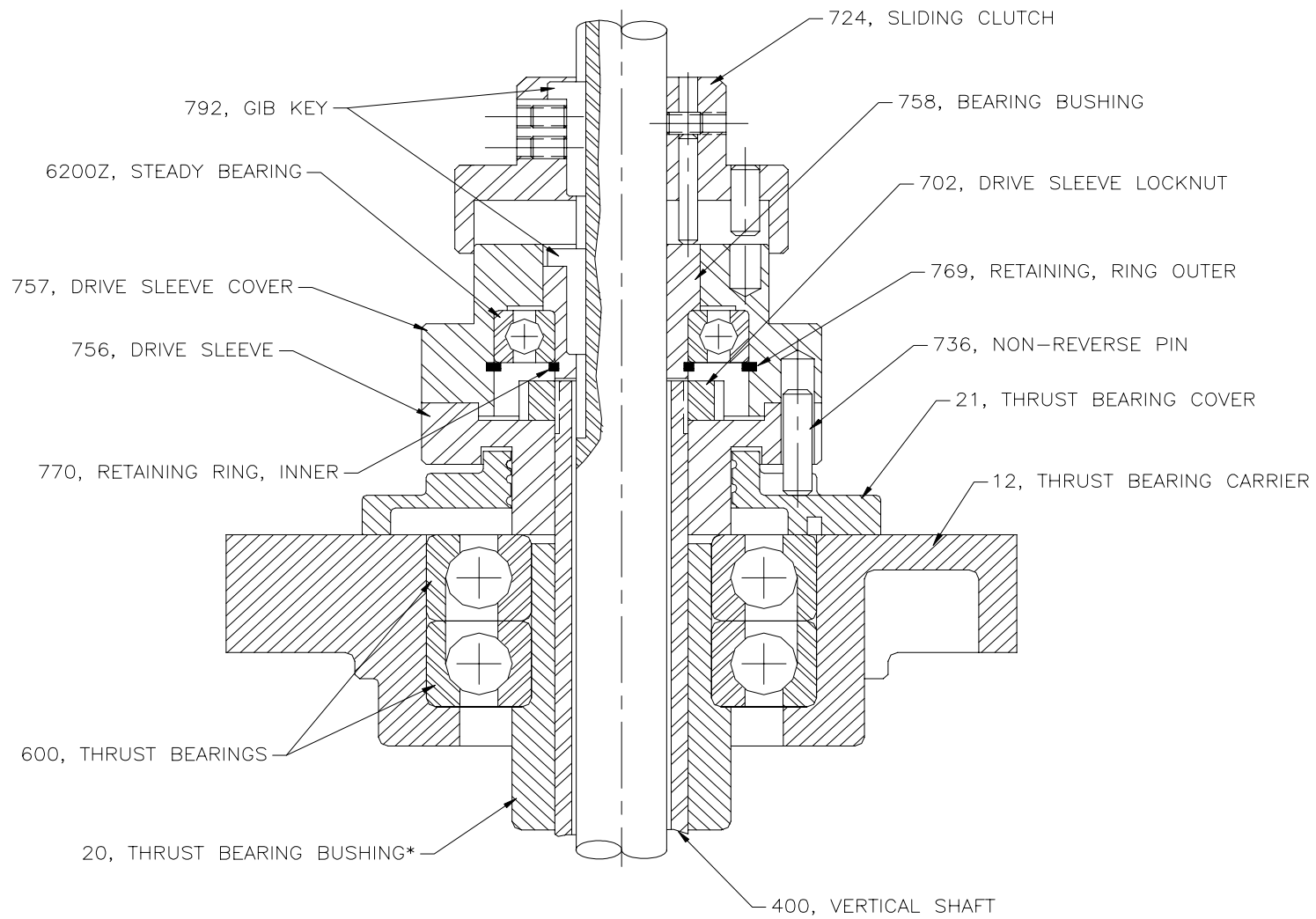

\* NOT USED ON ALL MODELS

DR.BY: R. ADAMS  
 CK.BY:  
 APP.BY:

**AMARILLO  
 GEAR  
 COMPANY**

TYPICAL  
 COMBINATION  
 CROSS SECTION

MODEL:	20-350
DATE:	11/26/02
PART NO.	
DWG NO.	2393